

Paradigm Environmental Technologies Inc.



Dr. Rob Stephenson,
Chief Technology Officer and Founder
October, 2010



Out of sight, out of mind, out of pocket

Municipal wastewater treatment plants:

- Hidden infrastructure, enormous costs
- Huge consumers of electricity and heat
- Most expensive item on property tax bill
- Excellent job in treating sewage to protect the environment



BUT

- Treat waste by product as a waste rather than extracting value

PARADIGM ENVIRONMENTAL TECHNOLOGIES INC.



MicroSludge is a sludge pre-treatment process that improves the conversion of waste sludge to renewable energy at wastewater treatment plants

PARADIGM ENVIRONMENTAL TECHNOLOGIES INC.



Waste activated sludge

- Microbes are tiny bags of liquid protected by tough membranes
- Rupture membranes to release cytoplasm containing biogas potential
- **Most effective cell rupture technology:**
High pressure homogenization

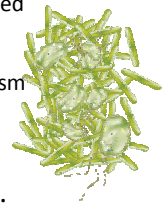

PARADIGM ENVIRONMENTAL TECHNOLOGIES INC.



MicroSludge cell disruption valve

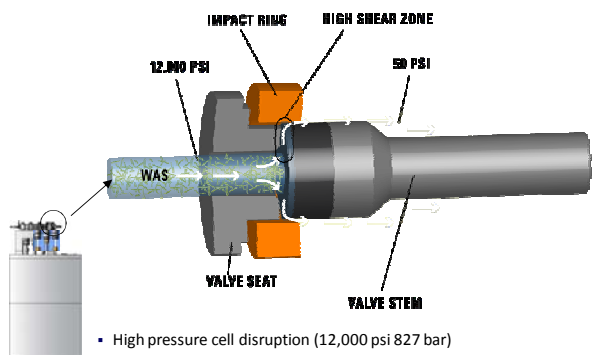

- High pressure cell disruption (12,000 psi 827 bar)
- Accelerates WAS microbes to 700 mph (310 m/s) through valve

PARADIGM ENVIRONMENTAL TECHNOLOGIES INC.



Cell lysis

Before MicroSludge

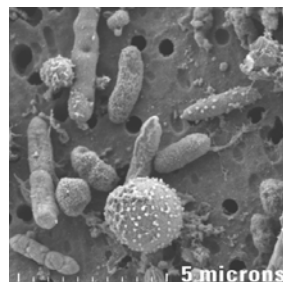

After MicroSludge

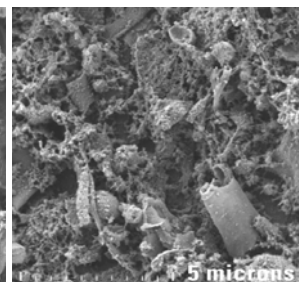

PARADIGM ENVIRONMENTAL TECHNOLOGIES INC.

MICRO SLUDGE

MicroSludge Benefits:

1. Reduced capital costs
2. Reduced operating costs



PARADISE ENVIRONMENTAL TECHNOLOGIES INC.

MICRO SLUDGE **Municipal WWTP – 200,000 people**

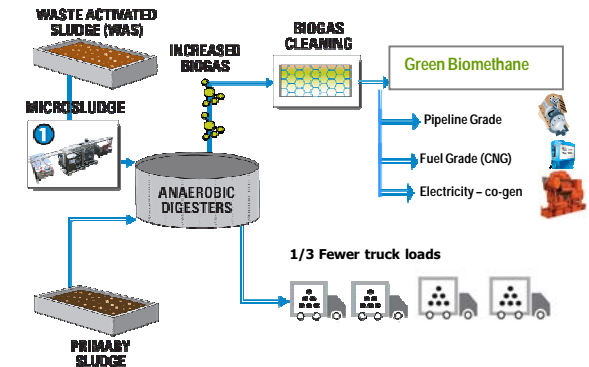

WASTE ACTIVATED SLUDGE (WAS) → INCREASED BIOGAS → BIOGAS CLEANING → Green Biomethane

Green Biomethane uses: Pipeline Grade, Fuel Grade (CNG), Electricity - co-gen

PRIMARY SLUDGE → ANAEROBIC DIGESTERS → 1/3 Fewer truck loads

PARADISE ENVIRONMENTAL TECHNOLOGIES INC.

MICRO SLUDGE **Increased digester throughput**

WWTP serving one million people



Primary Sludge WAS → 6 ANAEROBIC DIGESTERS

Primary Sludge WAS + MicroSludge → 6 ANAEROBIC DIGESTERS

MicroSludge Cost - \$15 M

= Saving \$100 MM

PARADISE ENVIRONMENTAL TECHNOLOGIES INC.

MICRO SLUDGE **MicroSludge for pulp and paper WAS**

FPInnovations

MicroSludge:

- Reduced digestion time of pulp WAS by 6 times
- More methane produced
- Less residual sludge for dewatering and disposal
- Nutrients recovered for reuse
- Lower GHG emissions
- Lower costs to manage sludge

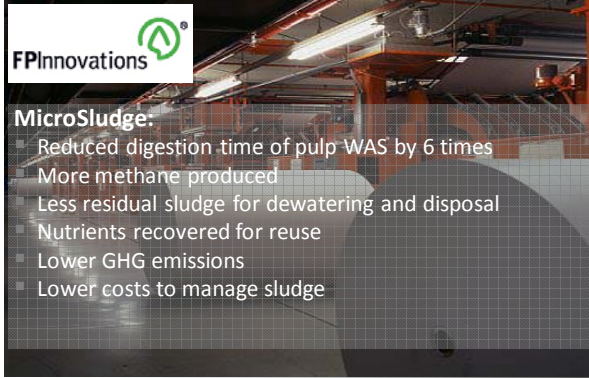

PARADISE ENVIRONMENTAL TECHNOLOGIES INC.

MICRO SLUDGE **Pulp mill effluent treatment plants**



WAS → High disposal cost

Waste to energy solution – recurring revenue

PARADISE ENVIRONMENTAL TECHNOLOGIES INC.

MICRO SLUDGE **MicroSludge markets**



Key municipal market drivers:

- Urban population growth
- Environmental regulations
- Exploding costs:
 - Build new infrastructure
 - Energy
 - Waste disposal

Industrial markets:

- Pulp and paper
- Food and beverage
- Petrochemical
- Pharmaceutical

PARADISE ENVIRONMENTAL TECHNOLOGIES INC.

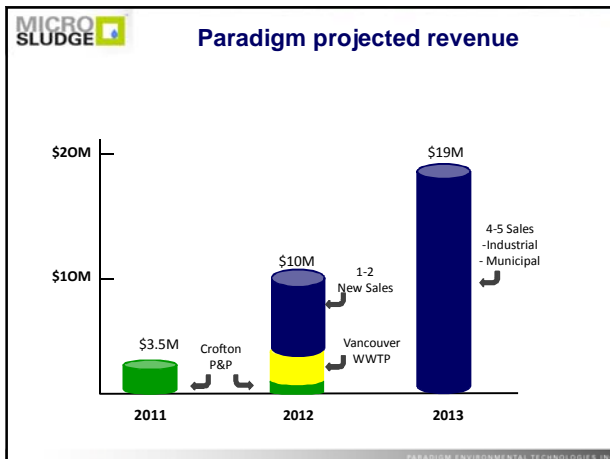

MICRO SLUDGE **Financing**

- Common equity raised: \$13.5 M
- Largest shareholders:
 - BC Discovery Fund: 17%
 - Strategic partner (APV): 14%
- Expansion Round (2011): \$3M+
 - Marketing and sales
 - Industrial and municipal reference sites

PARADIGM ENVIRONMENTAL TECHNOLOGIES INC.

- MICRO SLUDGE** **Intellectual property**
- Patent: new application of a proven technology
 - Awarded:
 - USA, Canada, EU, China, Mexico, Australia, Hong Kong, South Korea, India, Brazil
 - Proprietary “know how”
 - Significant barrier to entry
- PARADIGM ENVIRONMENTAL TECHNOLOGIES INC.

- MICRO SLUDGE** **Directors**
- Harry Jaako, Chairman, Principal of Discovery Capital Mgmt.
 - Michael Volker, President & CEO of GreenAngel Energy
 - Joseph Houssian, CEO of Elemental Energy Inc.
 - Philip Heller, President and CEO of McKenna Mgmt. Corp.
 - Dennis Morin, founder of Wonderware Software Development Co.
 - Len Williams, President, CEO and founder of Progressive Solutions
 - Gordon Skene, President and CEO, Paradigm
- PARADIGM ENVIRONMENTAL TECHNOLOGIES INC.

MICRO SLUDGE **Why Invest in Paradigm?**

Excellent value for industries and municipalities

- Reduced capital and operating costs
- Renewable energy from waste

Opportunity for Paradigm

- On-going needs by many markets
- Good profit margin, recurring revenue opportunities

PARADIGM ENVIRONMENTAL TECHNOLOGIES INC.